

Reference no. 1830 Date: 09.07.2019**TENDER CALL NOTICE****Selection of printing firms for supply of ODF Boards & Wall Paintings under IEC Campaign on ODF Plus (ODF+) under SBM-G.**

Sealed tenders in Double covers i.e. Technical & Financial Bid in prescribed formats (Format-1 & Format-2 prescribed in Bid Documents) are invited from reputed Concrete Slab Engraving firms/ wall paintings & printing firms for installation of ODF Boards & Wall Paintings as specified under Information Education and Communication (IEC) for creating awareness by conveying a standard message issued by Ministry of Drinking Water & Sanitation (MoDWS), Government of India through wall Paintings/ ODF Boards on ODF Plus (ODF+) that includes ODF-Sustainability & Solid Waste Management across Angul District.

The sealed tenders can be submitted through Registered/ Speed Posts only addressed to District Water & Sanitation Mission (DWSM), Angul, Collectorate, Post /Dist: Angul, Odisha by 24.07.2019 till 5.00 PM. No other mode of submission of Tender is allowed. The Tenders (Technical Bids) will be opened on 25.07.2019 at 4.00 P.M & financial bid of technically qualified bidders will be opened if time permits on the same day after opening technical bid in the presence of the committee members & the bidders or their authorized representatives in the conference Hall of DRDA, Angul.

The bidders are required to submit the Technical bid & Financial bid in two separate envelopes mentioned as Technical Bid & Financial Bid and both the envelope & both these two envelopes should be put into one larger envelope which should be super scribed as Tender Call Notice for IEC activities on ODF Plus under SBM-G of Angul District with Tender Call Notice No on it. All the bidders are requested to specify the nature of work as mentioned above on the top of the envelope containing the bid documents. The undersigned reserves the right to accept or reject any or all the Quotations without assigning any reason thereof.

The bidders are required to submit an EMD worth Rs. 68,000/- (Rupees Sixty Eight Thousand) only in shape of 2 years Fixed Deposit/ Term Deposit/ Postal Account Deposits duly pledged in favour of "District Water & Sanitation Mission (DWSM), Angul" from any nationalized bank along with the technical bid.

Further, the bidders are required to submit an amount worth Rs. 6,000/- (Rupees Six Thousand) only in shape of Demand Draft made in favour of "District Water & Sanitation Mission (DWSM), Angul" payable in Angul from any nationalized/ scheduled commercial bank towards cost of Bid Documents along with the technical bid.

The bidders applying for any one of the category are also required to submit the Bid paper Cost & EMD as specified. However bidders applying for both the categories can apply in one bid documents with EMD & Bid Paper cost as specified.

The Tender Documents received without EMD & Cost of Bid documents will be rejected.

The details of the Tender Call Notice can be viewed & the bid documents can be downloaded from the District website i.e. [www.angul.nic.in](http://www.angul.nic.in) from 10.07.2019 to 24.07.2019.

  
Collector & Chairman,  
DWSM, Angul



## Terms & Conditions

- The bidder must be a registered bidder only.
- The bidders must have a valid **GSTIN** number.
- The bidder must have a valid **PAN (Permanent Account Number)**.
- Rates to be offered for unit of item & also per Sqft as per the specification of the format/ Financial Bid.
- The bidders have to submit EMD worth **Rs. 68,000/- (Rupees Sixty Eight Thousand)** only in shape of **2 years Fixed Deposit/ Term Deposit/ Postal Account Deposits** duly pledged in favour of **"District Water & Sanitation Mission (DWSM), Angul"** from any nationalized bank along with the technical bid.
- Further, the bidders are required to submit an amount worth **Rs. 6,000/- (Rupees Six Thousand)** only in shape of **Demand Draft** made in favour of **"District Water & Sanitation Mission (DWSM), Angul"** payable in Angul from any nationalized/ scheduled commercial bank towards cost of Bid Documents along with the technical bid towards cost of Bid documents (Non-refundable).
- The sealed tenders can be submitted through **Registered/ Speed Posts** only addressed to **District Water & Sanitation Mission (DWSM), Angul, Odisha** by **24.07.2019 till 5.00 PM**. No other mode of submission of Tender is allowed. The Tenders will be opened on **25.07.2019 at 4.00 P.M** in the presence of the committee members & the bidders or their authorized representatives in the **conference Hall of DRDA, Angul**.
- The wall painting/ ODF Boards are required to be installed at village/ GP level of all the Blocks as per the specification provided.
- The rates quoted should inclusive of all taxes & charges including transportation etc.
- The undersigned reserves the right to deduct TDS under Income Tax & GST as applicable while making the payment of the bills.
- The work to be completed within **30 days** from the date of issuance of work order.
- Bidders have to submit one **experience certificate** for executing any Government/ PSU work of similar nature during last Financial Year. (The work order copy can be attached as a proof of the work executed). Further the bidder must have completed at least one assignment worth **Rs. 20.00 Lakh** during the last **03 financial year** for any Government organization (certificate from the competent authority/ work Order in which the amount has been mentioned or copy of agreement where value of the work has been mentioned).
- The bidder has to submit an **affidavit on Rs. 10/- (Rupees Ten)** only non-judiciary stamp paper with a declaration that the firm has not been blacklisted as well as the firm has no association with the employees of any of the employees of this office.
- The bidder has to submit the **Income Tax clearance certificate (IT Return)** for the **FY 2016-17, 2017-18 & 2018-19** along with the bid documents.
- The bidder has to submit the **Audited statements of accounts** for the **FY 2016-17, 2017-18 & 2018-19** along with the bid documents (Receipt-Payment, Income-Expenditure & Balance Sheet) under the seal & signature of a Chartered Accountant.
- The **average annual turnover** for the last **03 years** should be at least worth **Rs. 50.00 Lakh (Rupees Fifty Lakh)** only. The **turnover certificate** may be obtained from the Chartered Accountant firm under its seal & signature for the **FY 2016-17, 2017-18 & 2018-19**.
- Further the authority reserves the right to assign the work in favour of multiple firm/agencies/persons for early execution of the work for each of the category.
- The bidders can apply for any of the categories or can for both the categories if willing to.

- The successful bidder to execute an agreement in stamp paper worth Rs. 50/- (Rupees Fifty) only before issuance of order with the undersigned for execution of the work.
- The successful bidder to execute the work & complete the same before 15<sup>th</sup> August 2019. Failing which the EN will be forfeited and the bidder will be blacklisted.
- The authority reserves the rights to reject any or all the quotations without assigning any reason thereof.
- Any dispute in this matter is subject to Angul Jurisdiction only.

  
Collector & Chairman,  
DWSM, Angul

Memo No. 1831 / Dated: 09.07.2019

Copy forwarded to Additional District Magistrate, Angul for information and necessary action with reference to District Office (I & PR Section) Letter No: 1023 Dt: 22.12.2017. He is requested to display the Short Quotation Call Notice on the notice board of the District Office.

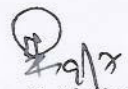
  
Collector & Chairman,  
DWSM, Angul

Memo No. 1832 / Dated: 09.07.2019

Copy forwarded to All Sub-Collectors/ All BDOs / All Tahasildars / All Executive Officers ULBs of Angul District for information. They are requested to publish the Tender Call notice on the notice board of their offices for wide publication.

  
Collector & Chairman,  
DWSM, Angul

Memo No. 1833 / Dated: 09.07.2019

Copy forwarded DIO, NIC, Angul for information. He is requested to webhost the Tender Call notice & Bid Document in the District website for wide publication & he is also requested to please provide download option to the intending bidders for download of the bid documents.

  
Collector & Chairman,  
DWSM, Angul



**Specifications of Works to be executed under IEC Campaign for Plus under Swachha Bharat Mission (SBM).**

1. **Wall Paintings (Annexed at Templates #2 (A,B,C & D))**
  - a) The wall paintings will capture the following messages:
    - i) Toilet usage by all (Children, Youth & elderly)
    - ii) Toilet usage to keep diseases away.
    - iii) Safe disposal of Child faeces.
    - iv) Compost Pits.
  - b) The designs have been developed in Odia and the art work for the same is attached (Annexed) for reference.
  - c) The wall paintings can be painted on the walls of various public places such as Schools, Anganwadis, Panchayat Building, Health Centre, Post Office, Bus Stand etc.
  - d) The minimum size of each wall painting should be (6 feet \* 4 feet).
2. **ODF Boards (Annexed at Templates #1)**
  - a) A Board Declaring the ODF status of an ODF achieved village shall also be installed at the entrance of the village.
  - b) The ODF Board is required to be built out of precast concrete slab with 02 nos of pillar of size (4" X 4" X 2'.0").
  - c) The Minimum size of ODF Board should be
    - 1-Pre Cast Slab- [4 feet (Width) \* 3 feet (Height) \* 4 inches (Thickness)]
    - 2-Pre Cast Concrete Legs- 2 feet of size (4" X 4" X 2'.0")
    - 3-Pre Cast Slab on ground- each side on 1 feet square precast slab (1' X 1' X 0.4") to hold the legs of ODF board)
  - d) The design template of the ODF Board is annexed and the design can also be downloaded from SBM website ([www.sbm.gov.in](http://www.sbm.gov.in)) >IEC Material>Sanitation>4+1 IEC Collaterals.

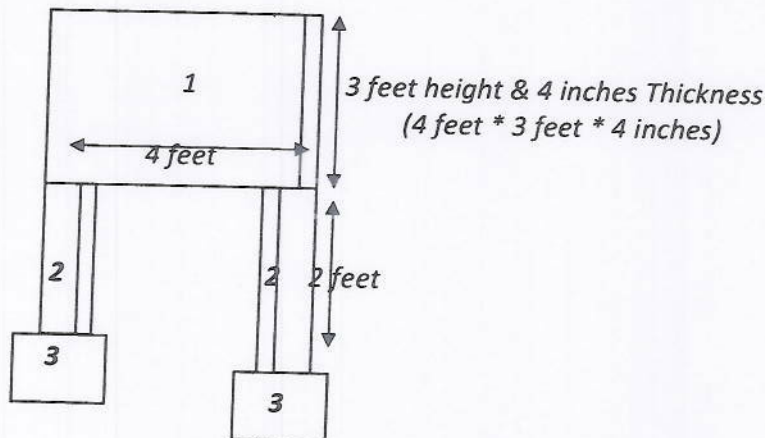

Pre cast slab (2 nos on each leg) 1' X 1' X 0'.4"

  
Collector & Chairman,  
DWSM, Angul

TEMPLATES

1. ODF

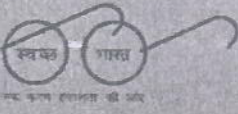

ବାହ୍ୟ ମଳମୁକ୍ତ ଗାଁ

ଆପଣଙ୍କୁ ସ୍ୱାଗତ କରୁଛି  
ଆମେ ଗାଁକୁ ସୁଚ୍ଛ ରଖିବାପାଇଁ ପ୍ରତିବନ୍ଧ ଅଟୁ



ବାହ୍ୟ ମଳମୁକ୍ତ ଯୋଗଣା ତାରିଖ \_\_\_\_\_

2. Wall Paintings

|| |

A



ଶୌଚାଳୟ ଅଟେ ସମସ୍ତଙ୍କର,  
ଶିଶୁ, ବୃଦ୍ଧ ଆଉ ଯୁବକଙ୍କର



  
Collector, Angul



B



C



D

Pran

Collector, Angul

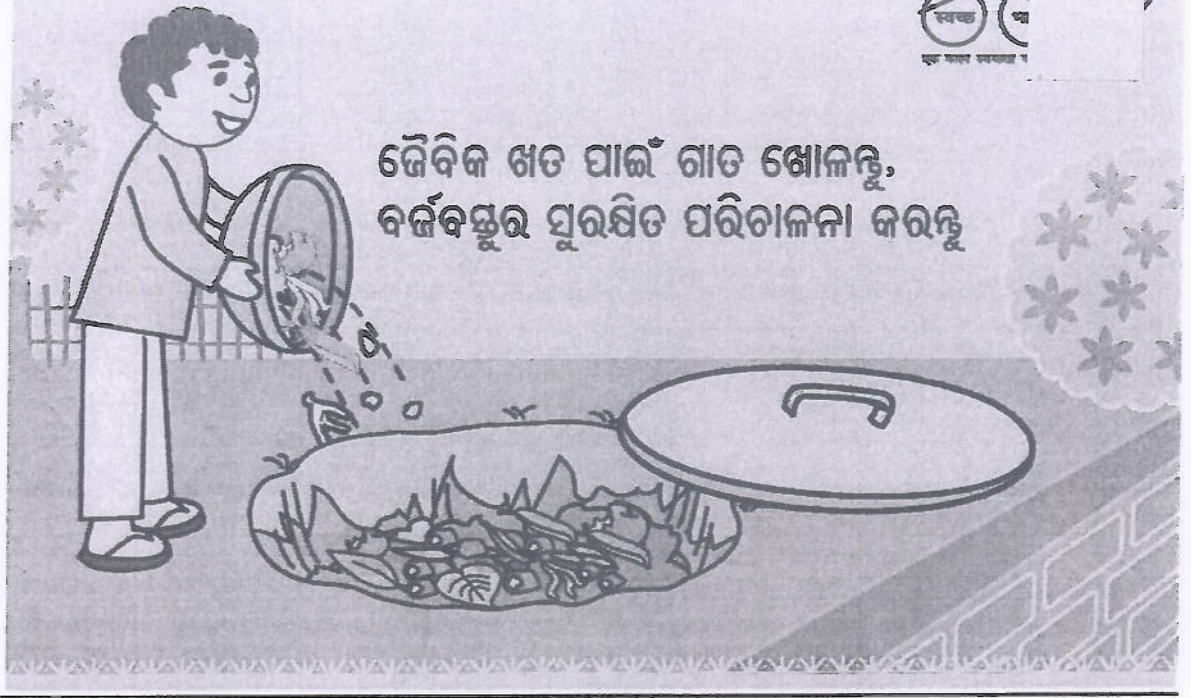

ଜୈବିକ ଖତ ପାଇଁ ଗାତ ଖୋଳନ୍ତୁ,  
ବର୍ଜବସ୍ତୁର ସୁରକ୍ଷିତ ପରିଚାଳନା କରନ୍ତୁ

  
Collector & Chairman,  
DWSM, Angul